

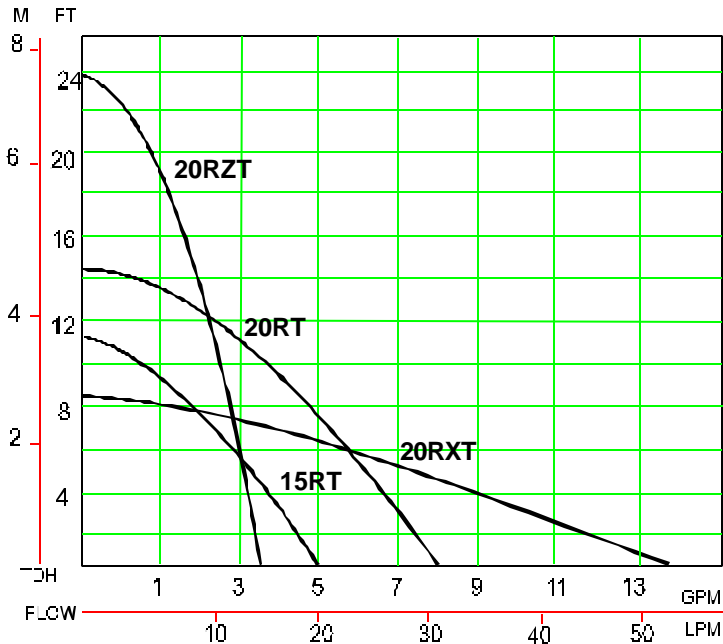

IWAKI WALCHEM Corporation

MD-15/20



- Twin bearing system handles thrust loads, extends service life
- Hollow rotating / Internal cooling circuit reduces bearing temperature
- Compact / Quiet energy efficient design
- Few moving parts for easy maintenance
- Other sizes, voltages & materials available

Part	Material
1 Casing	GFRPP
2 Impeller	GFRPP or CFRPP
3 Spindle	Ceramic
4 Bearing	PTFE
5 Thrust ring	Ceramic or PE
6 O-ring	FKM or EPDM

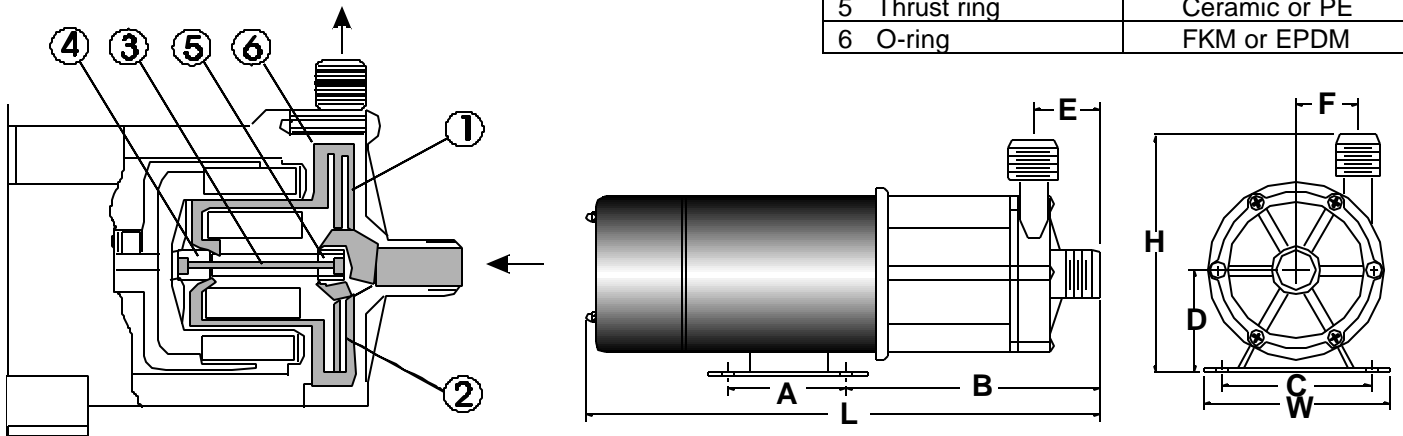

Dimensions (inches) and Specifications

Model	W	H	L	A	B	C	D	E	F
MD-15R(T)	3.74	4.49	7.05	--	4.59	3.35	2.17	1.52	0.85
MD-20R(T)	4.17	4.19	8.00	1.73	3.78	3.54	1.77	1.30	1.12
MD-20RX(T)	4.17	4.80	8.66	1.73	4.45	3.54	1.77	1.83	15+
MD-20RZ(T)	4.17	4.92	8.31	1.73	4.17	3.54	2.17	1.56	1.52

+ Degrees offset from vertical

Model	CONNECTIONS		MOTOR		AMPS 115V	MAX FLOW GPM	MAX HEAD FT	MAX SYS PRESSURE PSI	S.G.	WEIGHT LBS
	HOSE	NPTM	OUTPUT (HP)	SPEED (RPM)						
MD-15R(T)	½	½	1/75	3100	.29	5.0	11.1	7.2	1.3	4
MD-20R(T)	5/8	3/4	1/38	3100	.48	8.2	14.1	10.0	1.1	4
MD-20RX(T)	1	1	1/38	3100	.50	13.7	8.2	5.7	1.3	4
MD-20RZ(T)	5/8	¾	1/38	3100	.53	2.9	22.6	14.2	1.1	4