



## Bak-Pak™ 2 WITH ACCELA PUMP

The importance of the protein skimmer in the modern marine aquarium has been acknowledged by aquarists worldwide, but until now these skimmers required the use of a sump and expensive modifications to the tank. The Bak-Pak™ 2 is designed to provide a combination protein skimmer/biological filter that simply hangs on the back of the aquarium with no plumbing required. The Bak-Pak™ 2 can be used to replace or supplement an existing system and comes complete with the new Accela pump and our Bio-Bale™ filter media. The Bak-Pak™ 2 has been improved over the original Bak-Pak™ with the addition of an enclosed directional outflow to reduce salt creep, a removable inlet for easy cleaning, and a new break resistant collection cup.

To place your Bak-Pak 2™ into operation:

1) Carefully remove all packaging and inspect the unit for damaged or missing parts. You should have:

- |   |  |
|---|--|
| (1) Skimmer body                          | (1) Inlet assembly                       |
| (1) Accela pump                           | (1) Bio-Bale™ filter media               |
| (1) Airline tubing with air control valve | (1) Collection cup with "O" ring and lid |
| (1) Outlet assembly                       |  |

**If any items are damaged or missing, please contact your dealer immediately.**

2) Attach the powerhead to the inlet assembly as shown (Diagram A) and hang the Bak-Pak™ 2 on your tank.\*\* Use the adjustment screws to position the Bak-Pak™ 2 so that it is parallel to the back of the tank.

\*\* If the powerhead does not fit through the opening of the aquarium, place the Bak-Pak™ 2 on the tank and insert the powerhead into the inlet from inside the aquarium. Make sure that the muffler on the end of the long air line is outside of the water at all times. A black clip is provided at the top of the unit to hold the airline.

3) Clean the collection cup including the throat of the funnel in hot water. This will cause the skimmer to begin collecting waste faster. Do not use any detergents on the collection cup. Insert cup into the protein skimmer section with O-ring around the outside.

4) Plug in the powerhead. Your Bak-Pak™ 2 is now operational.

5) The base of the collection funnel should be 1/8" below the water surface for optimal performance. Slide the O-ring up or down until the desired skimmate wetness is achieved.

6) The air valve on the airline will allow you to control the amount of air being drawn into the powerhead. We recommend opening the valve completely for maximum air flow into the skimmer. If bubbles do not reach the bottom of the skimmer column, slowly close the valve until the column is full.

7) If turbulence bubbles are coming out of the outlet pipe, adjust the endcap on the pipe so that half the outlet is exposed and out of the water. The outlet can be made shorter or lower by adjusting (up or down) or by reversing the endcap (notice one side is shorter). (See Diagram B) This will allow the bubbles to vent out of the opening without being pushed into the aquarium.

**It is common that some of the micro-bubble escape to the tank for the first 48 hours. It will stop after the break-in period**

## MAINTENANCE

- 1) The collection cup should be emptied regularly. Every time you empty the cup, clean the base of the funnel and the inside of the throat for better collection.
- 2) The Bio-Bale™ should be cleaned every three months, or as needed. Remove the Bio-Bale™ filter media and place it in a bucket of saltwater. Swish the Bio-Bale™ around in the water to remove any algae or detritus. Shake off any excess water before returning it back to the bio chamber of the Bak-Pak™ 2. Never use detergents of any kind on the Bio-Bale™ and do not allow it to dry out. Make sure not to pack the Bio-Bale™ too tightly when placing it back into your Bak-Pak™ 2.
- 3) **Clean the powerhead at least once a month. Replace the powerhead every twelve to eighteen months to ensure optimal performance**
- 4) The inlet and outlet may be removed and cleaned as needed. Be sure to replace the washers on each assembly when reassembling your Bak-Pak™ 2. With the fittings removed the body can be cleaned with warm tap water and an algae scrubber. **Be careful when removing and assembling the inlet and outlet fittings. Do not over-tighten these fittings as this may cause them to break.**

## REMOVAL AND CLEANING OF YOUR POWERHEAD

- 1) Slide the powerhead out of the inlet of the Bak-Pak™ 2.
- 2) Remove air line and the intake screen by pulling away from the powerhead.
- 3) Remove base plate by lining up the flat portion to the locking guide. Pull the base straight away from the powerhead as the impeller may be attached to it.
- 4) Wash all parts under warm tap water. Do not use any detergents. Make sure that the air line is clear of any foreign matter, calcium buildup or salt creep before reassembling.
- 5) Reassemble the powerhead and place it back on your Bak-Pak™ 2.

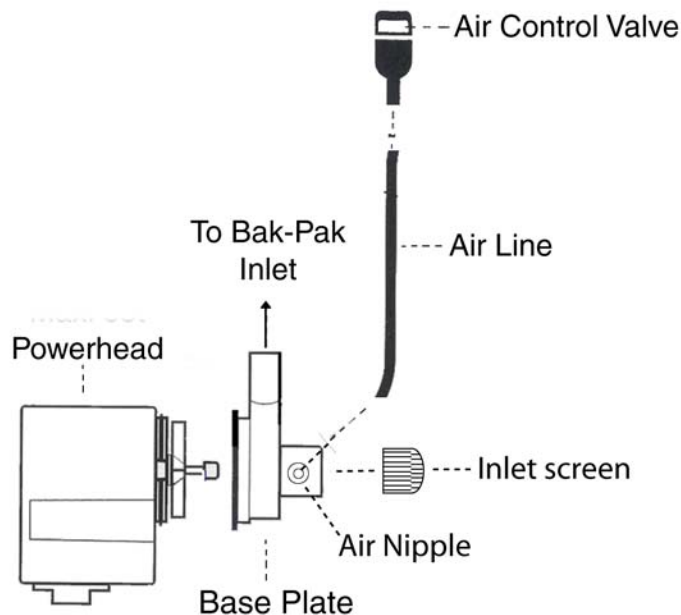

## TROUBLE SHOOTING

Problem:	Cause and Solution:
Small air bubbles returning to the tank	The surface tension of the water has been increased by the addition of additives, medications, or conditioners. Disable the protein skimmer by submerging the airline into the water (remove muffler first) or shutting off the air valve for 24 hours. Many products contain chemicals which will still be present in the aquarium after 24 hours. Running the protein skimmer as well as the use of activated carbon will help to remove compounds which may be affecting surface tension.
	The salinity is too high. Lower the salinity to 1.023.
	The aquarium has just been cleaned or water has been changed. Synthetic salt mixes often contain conditioners which increase the surface tension of the water. Bubbles should disappear within 24 hours.
	The air line is clogged with detritus or salt creep. This will increase the water flow rate and possibly sweep the bubbles from the skimmer chamber back into the tank before they can dissipate. The airline should be cleaned every two weeks.
	The Bio-Bale has been removed. The Bak-Pak 2 is designed so that a small amount of air escapes into the Bio-Bale chamber to support the bacteria. If you decide to use the Berlin method of filtration and remove the Bio-Bale you may purchase the Bak-Pak Bubble Trap (BPBT) which slides into the chamber, or the NBT Bubble Eliminator, which slides over the outlet of the Bak-Pak 2.
	The outlet can be made shorter or lower by adjusting (up or down) or by reversing the endcap (notice one side is shorter). (See Diagram B) This will allow the bubbles to vent out of the opening without being pushed into the aquarium.
Bubbles escaping from the powerhead into the tank.	The base plate or venturi adapter is not properly sealed. Remove the plate and make sure no detritus or calcium buildup is preventing the plate from sealing properly. Be sure not to break or bend the two clips which hold the plate in place.
No waste collecting in collection cup.	The powerhead and its air line may be dirty. Clean the whole unit every two weeks for optimal performance.
	The collection cup is not low enough. See instructions for the correct height of the collection cup.
	The biological load may not be sufficient to generate waste. On a new tank or a tank with supplemental filtration it may take over a week to generate waste foam.
	Skimmer chamber is not filled with micro bubbles. Slowly close the air line valve until the chamber is filled with bubbles.
Water is flowing through the safety hole in the center divider.	The Bio-Bale is packed too tightly. Remove the Bio-Bale and reposition it so it doesn't restrict water flow.
The pump is producing little or no bubbles.	The airline or the air control valve may be blocked. Detritus, calcium and salt will build up in these parts over time. Clean these parts every two to three weeks with warm tap water.
	The powerhead may need to be cleaned. If the powerhead becomes clogged with organic material the flow rate and the air intake rates will reduce. Follow the instructions included with your Bak-Pak 2 to clean your powerhead.
Tank has high ammonia or nitrite readings.	Your tank may not have completed the nitrogen cycle. This process can take up to 8 weeks in fish-only systems.
	It may be necessary to clean the Bio-Bale. Follow the instructions included with your Bak-Pak 2 to clean the Bio-Bale.
	If you find that it is necessary to clean the Bio-Bale more than once every couple of months, you may be over feeding your tank. Please consult your local fish store about the proper feeding of your tank.

**Before calling CPR's Technical Support, please take some time to look over this trouble- shooting guide. Most of the problems associated with the performance of the Bak-Pak™ 2 are due to improper maintenance of the Accela powerhead. Cleaning the powerhead at least once a month will ensure optimal performance of the Bak-Pak™ 2.**

**Diagram A**

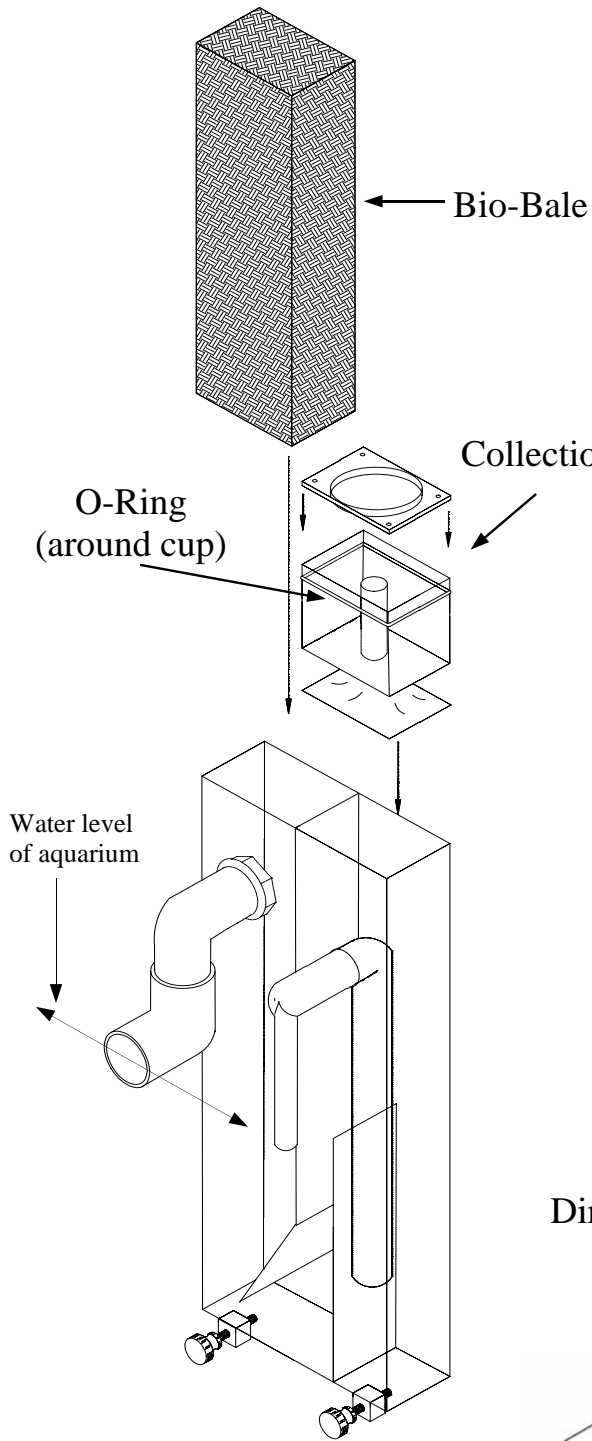

**WASHER PLACEMENT**

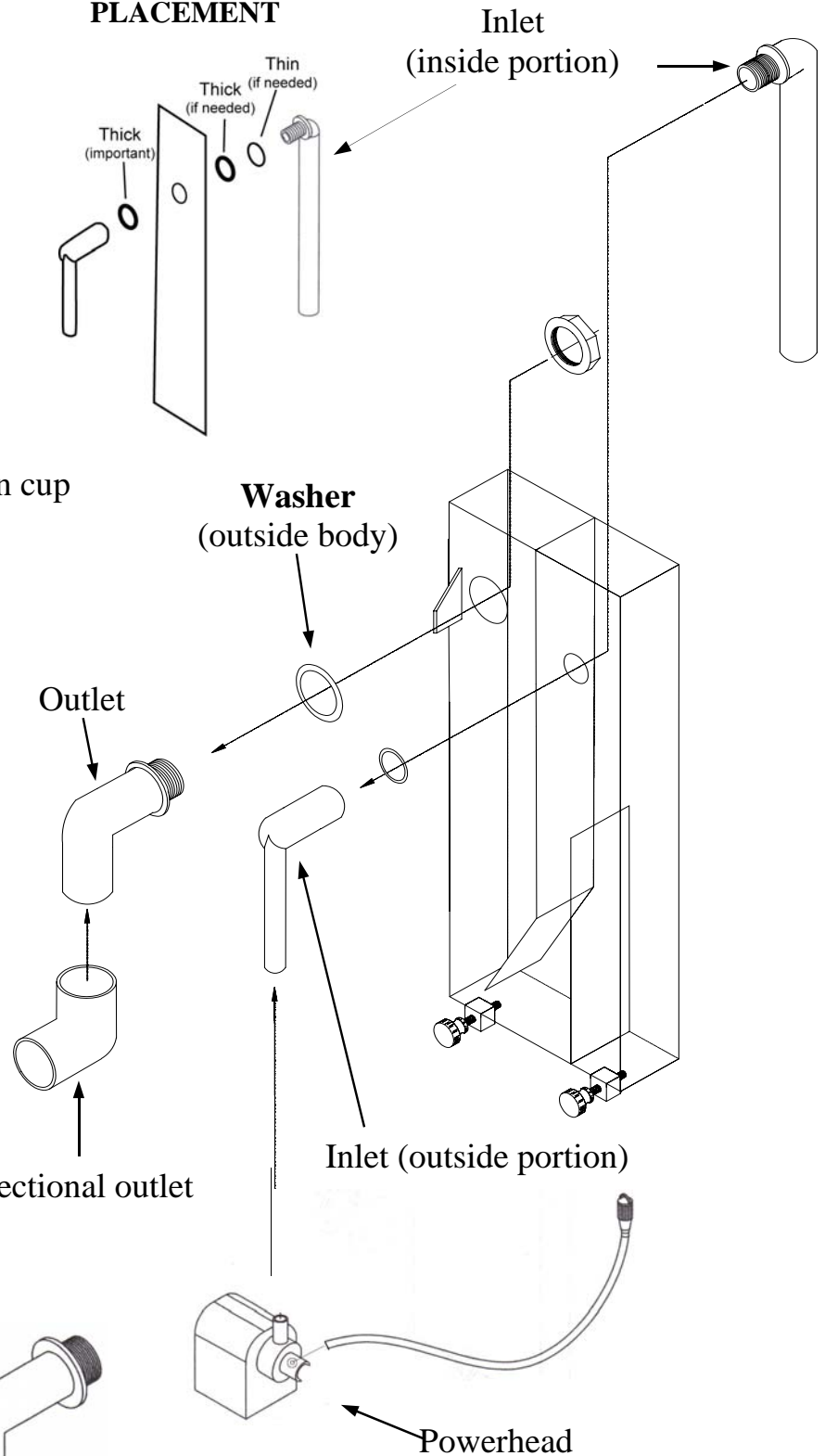

**Diagram B**

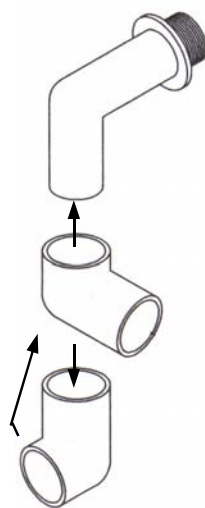

To minimize turbulence bubbles returning to the tank, adjust the outlet so that it is placed relative to the water level as shown.

The outlet elbow can be flipped around and adjusted up and down the primary outlet piece to achieve the desired height. For users with high tank water levels, the outlet can be further adjusted by loosening the bulkhead fitting on the outlet and rotating the entire outlet to achieve the desired height. It is also acceptable for the water to exit the elbow in a slightly upward manner.